

Environmental Challenges Panel Refiner Overview API Tanker Conference

**Ken Applegate, VP Transportation Services
Valero Marketing and Supply**

Supply & Demand Balances

WORLD DEMAND FOR PETROLEUM INCREASED FROM 78 MILLION BARRELS PER DAY (MBPD) IN 2002 TO 87 MBPD IN 2008.

THIS GROWTH IS EXPECTED TO REACH 96 MBPD IN 2015 AND 113 MBPD IN 2030.

(Source: International Energy Outlook 2008)

- **United States demand** for petroleum
 - 19.8 mbpd in 2002 to 20.9 mbpd in 2008
 - Expected to reach 21.5 mbpd in 2015 and 22.1 mbpd in 2030
- **Far East demand** for petroleum
 - 21.5 mbpd in 2002 to 25.5 mbpd in 2008
 - Expected to reach 30.2 mbpd in 2015 and 39.2 mbpd in 2030

Global Energy Market

World Oil Consumption by Region and Country Group 2004 and 2030

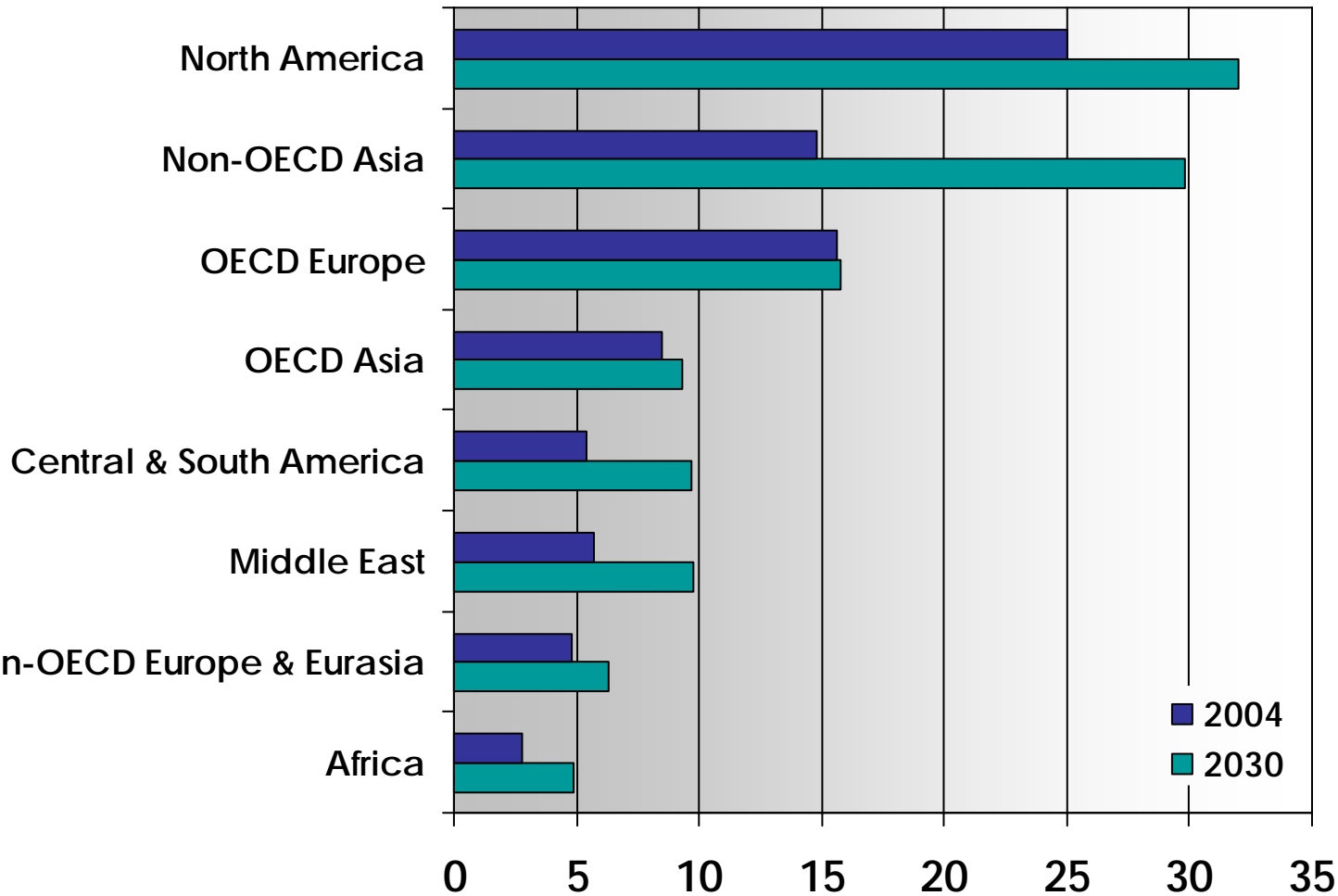

Sources:

2004: Derived from Energy Information Administration (EIA). *International Energy Annual 2004 (May-July 2006)*.

Web site

www.eia.doe.gov/iea/.

Projections: EIA System for the Analysis of Global Energy Markets (2007).

On-Road Diesel Sulfur Specifications (ppm)

COUNTRY (REGION)	2005				2006				2007				2008				2009				2010				2011				2012			
	1Q	2Q	3Q	4Q	1Q	2Q	3Q	4Q	1Q	2Q	3Q	4Q	1Q	2Q	3Q	4Q	1Q	2Q	3Q	4Q	1Q	2Q	3Q	4Q	1Q	2Q	3Q	4Q	1Q	2Q	3Q	4Q
NORTH AMERICA																																
United States	500				15 (80% of the Pool)												15															
Canada (Average)	500				15																											
Mexico	500				500/15 (NW Mexio & Other areas)												15															
EUROPE AND FSU																																
European Union (Max)	50								10																							
Russia (Max)	350 (Moscow & Certain Other Cities, Int. Border Areas), 500 (City)																															
SOUTH AND CENTRAL AMERICA																																
Venezuela	5000																															
Brazil	3500/2000				2000/500 (Non-urban / Cities)																											
Argentina	1500								50 (Buenos Aires, Cardoba, Santa Fe, Mendoza) / 500																							
ASIA PACIFIC																																
Japan	50								10																							
China	500				500/350/50 (Nationwide / Beijing / Hong Kong)												50/10 (Nationwide / Hong Kong)															
South Korea (Max)	430				30																											
India	2500/500				500/350 (Nationwide / Select Cities)												350/50 (Nationwide / Select Cities)															
AFRICA AND MIDDLE EAST																																
Saudi Arabia	10,000				10,000/500 (Nationwide / Large Cities)												500/50 (Nationwide / Large Cities)															

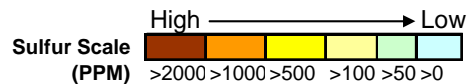

Three Standard Crude Types

Crude Types

Characteristics

Yields

U.S. Refinery Production

Sweet Crude
(i.e. WTI, Bonny Light, Tapis)

34+ API Gravity
< 0.5 % Sulfur
Most Expensive

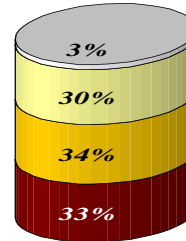

8% Propane/Butane

Medium Sour Crude
(i.e. Mars, Basrah, Arab Medium)

24 - 34 API Gravity
> 1.0 % Sulfur
Less Expensive

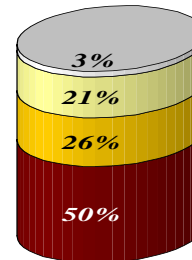

49% Gasoline
RFG
Conventional
CARB
Premium

Heavy Sour Crude
(i.e. Maya, Ratawi, Oriente)

< 24 API Gravity
> 1.0 % Sulfur
Least Expensive

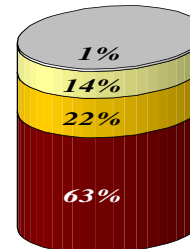

32% Distillate
Jet Fuel
Diesel
Heating Oil

11% Heavy Fuel Oil
& Other

Crude Trends Favor Sour Crudes

2006 World Crude Demand by Quality

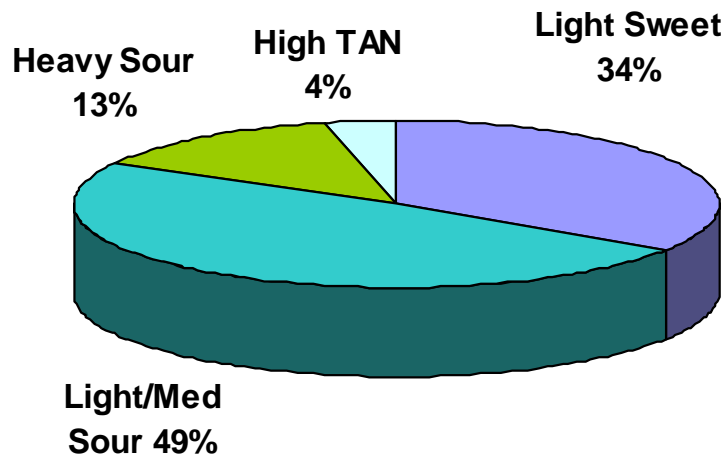

2010-2015 Estimated World Crude Supply Growth, MBPD

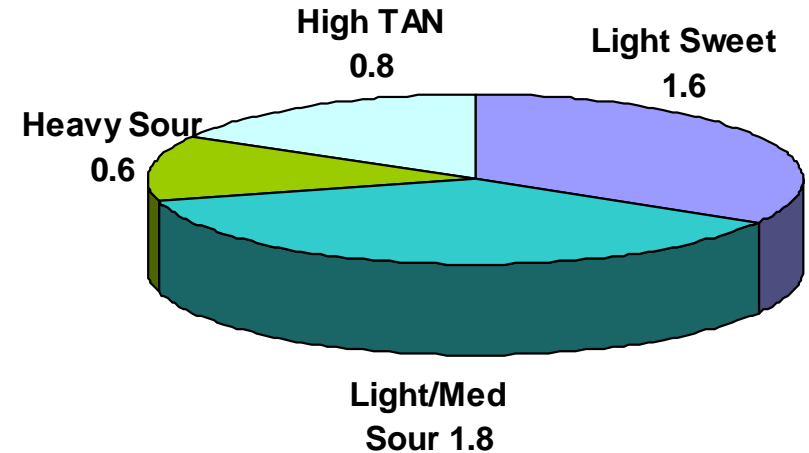

- **Sweet crude demand far outpaces sweet crude reserves**
Driving up prices for sweet crudes

Source: EIA

Three Basic Types of Refineries

Crude Types

Topping Plants
Hydroskimming
Refinery

Characteristics

Crude Unit (CDU)
Reforming Unit
Desulfurization Unit
Least Expensive

100%

Yields

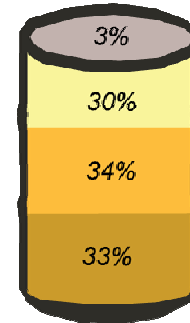

Plants with
Crackers
Medium Conversion
Plants

All units above plus
Fluid Catalytic Cracker
Alkylation Unit
More Expensive

104%

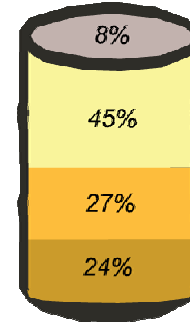

Plants with
Cokers
High Conversion
Plants

All units above plus
Hydrocracker
Coking Unit
Most Expensive

108%

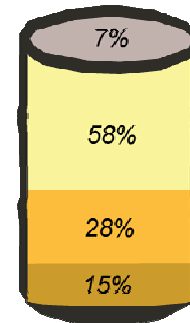

2008 U.S. Refinery Production

8% Propane/
Butane

49% Gasoline
RFG
Conventional
CARB
Premium

32% Distillate
Jet Fuel
Diesel
Heating Oil

11% Heavy
Fuel Oil
& Other

Source: EIA Refiner Production

Hydroskimming Refineries – Distillation Process

Light
Sweet
Crude

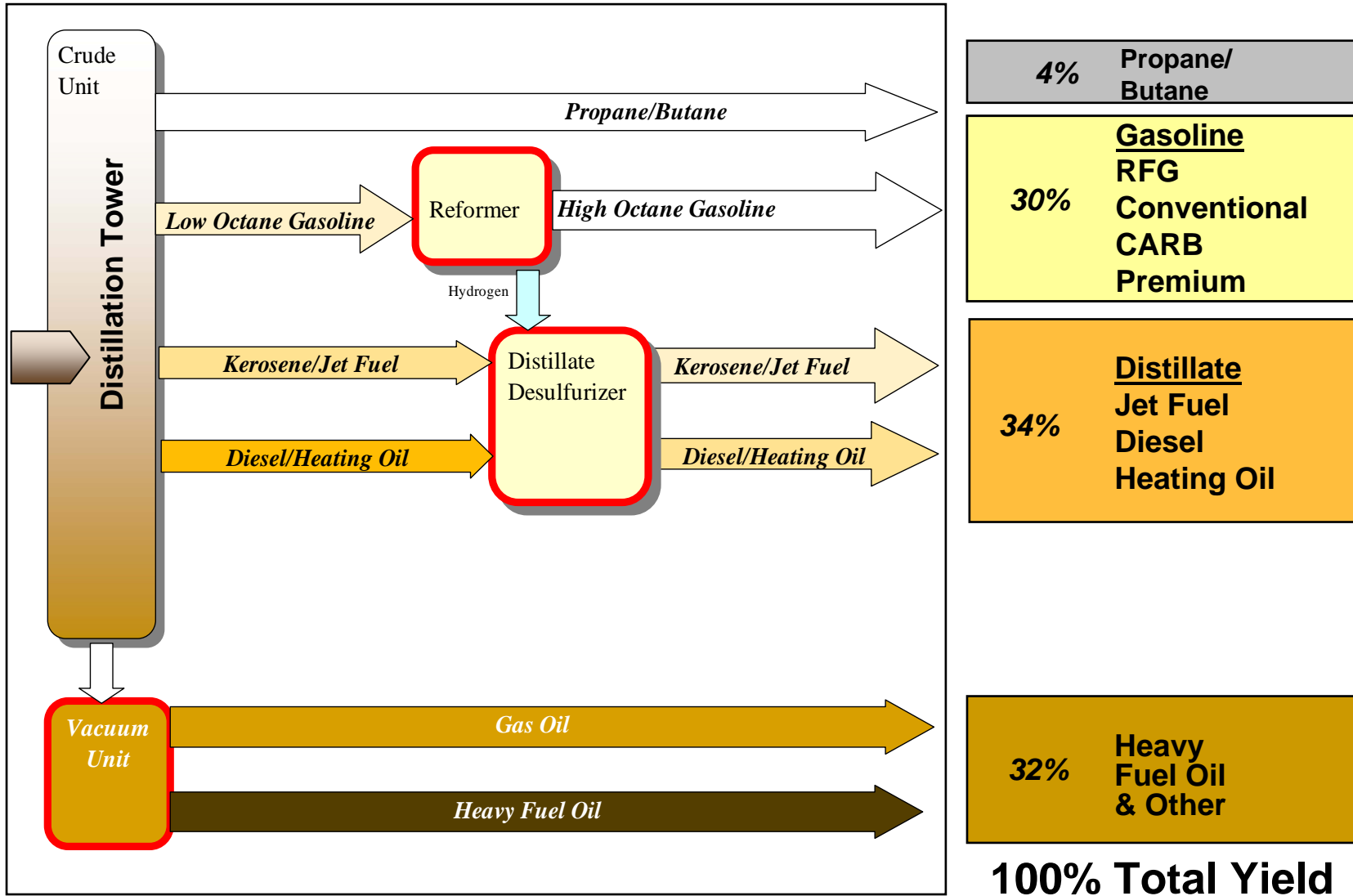

Simple low upgrading capability refineries tend to run sweet crude

Medium Conversion Refineries - Catalytic Cracking

Light Sour Crude

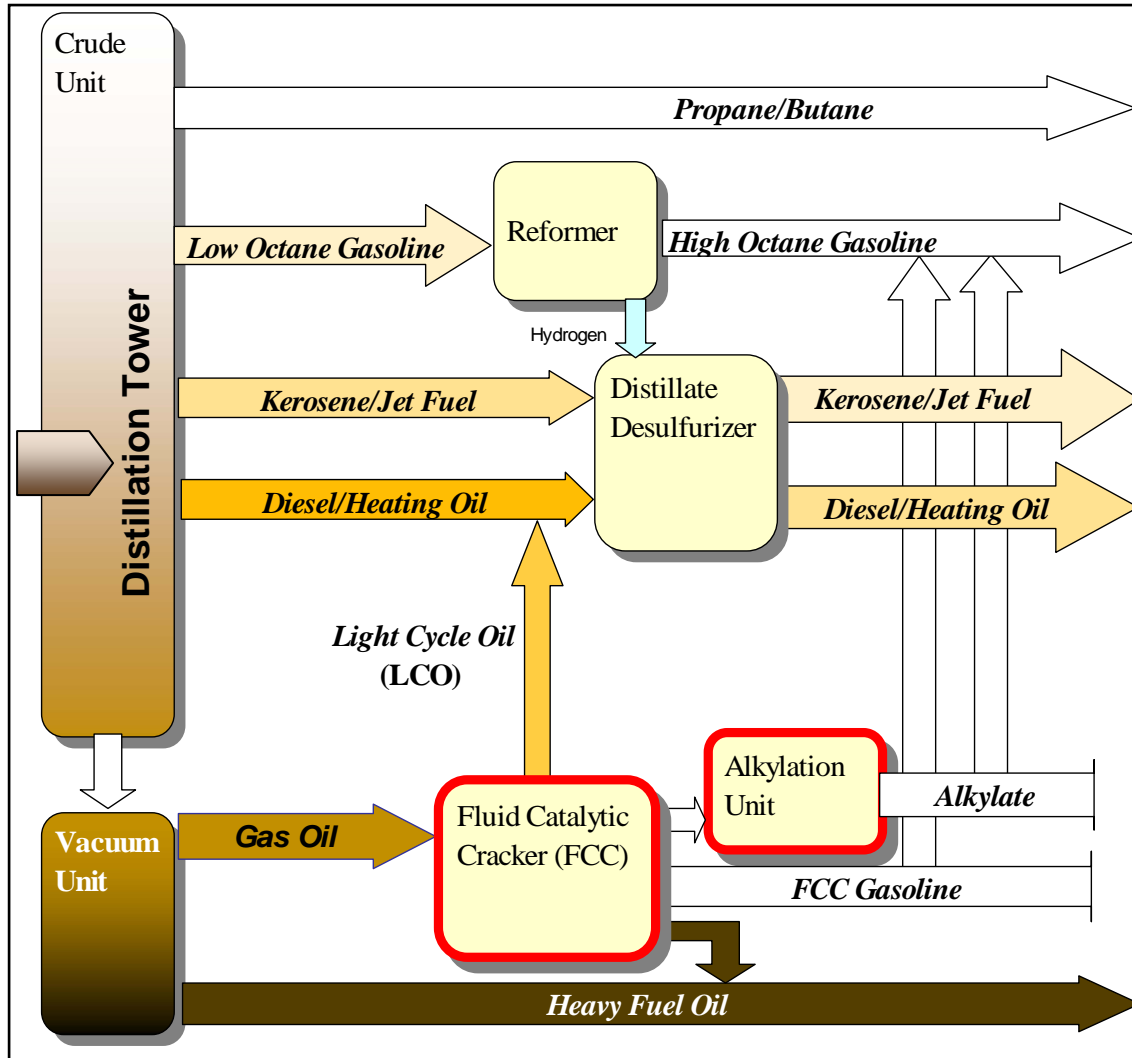

8%	Propane/ Butane
45%	<u>Gasoline</u> RFG Conventional CARB Premium
27%	<u>Distillate</u> Jet Fuel Diesel Heating Oil
24%	Heavy Fuel Oil & Other

104% Total Yield

Moderate upgrading capability refineries tend to run more sour crudes while achieving increased higher value product yields and volume gain.

High Conversion Refineries – Coking/Resid Destruction

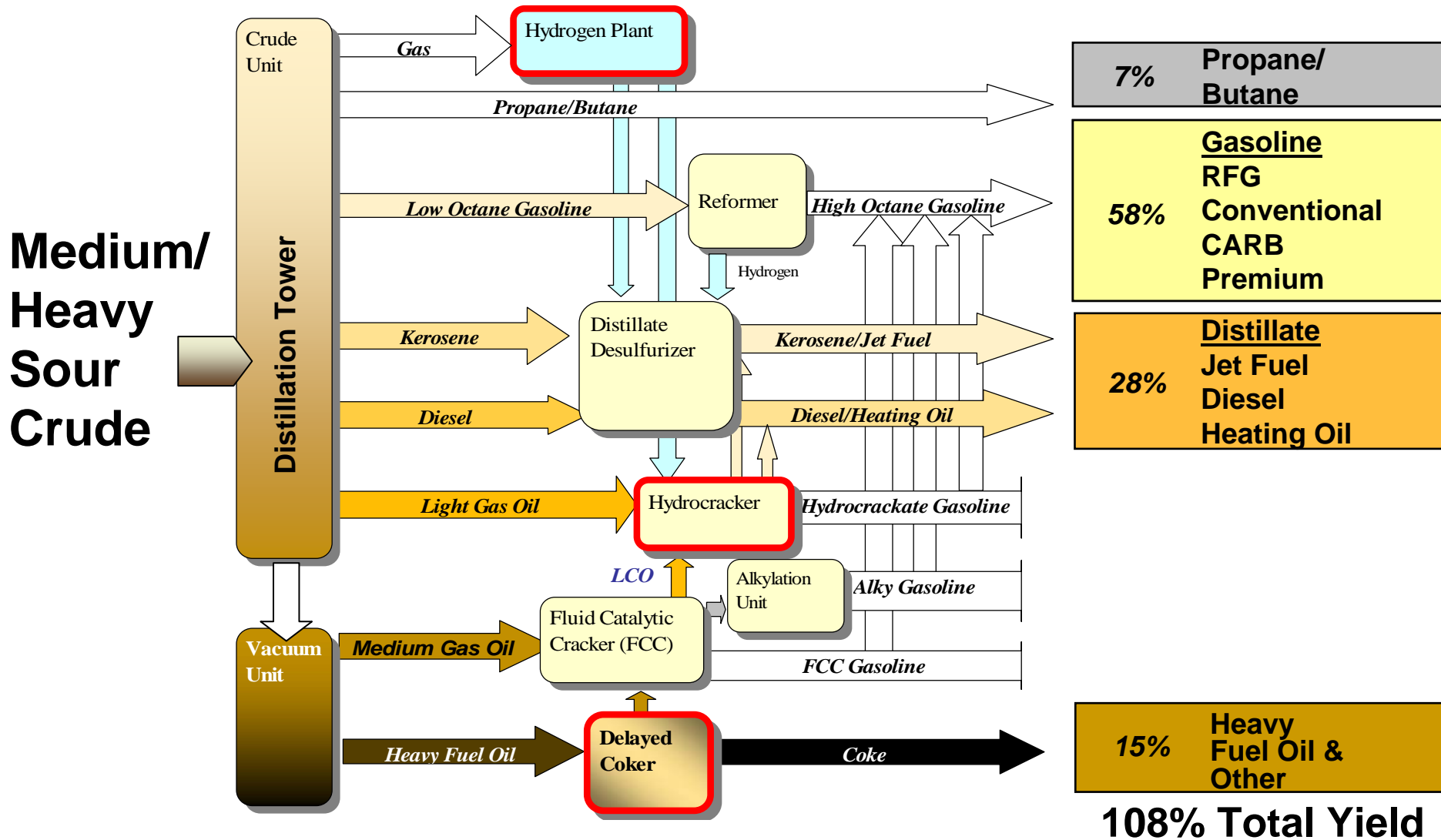

Complex refineries can run heavier and more sour crudes while achieving the highest light product yields and volume gain.

Estimated Refinery Unit Construction Costs

<u>Unit</u>	<u>Capacity</u>	<u>Construction Costs</u>
Diesel Hydrotreater	50 M BPD	\$200-\$250MM
Hydrocracker	50 M BPD	\$800-\$1,000MM
Coker	45 M BPD	\$650-\$800MM
Hydrogen Plant	100 MM SCFD	\$125MM

Significant capital expenditures will be required to meet global fuel demand

Project Construction Challenges

- Long lead times to secure environmental and construction permits in many areas.
- Cost inflation in construction materials.
- Long lead time delivery period for critical equipment.
- Availability of experienced craftsman in certain trades.
- In existing refineries, site layout and congestion/complexity triggered by proximity to operating units.
- In grass roots facilities, construction of basic utilities may be required and greater site preparation required.

Summary

- Global growth in hydrocarbon fuel consumption is expected to continue to be robust.
- The refining industry has historically demonstrated its ability to meet tighter fuel specifications and cover overall global energy demand while processing more difficult feedstocks.
- Keys to success
 - Finalizing the various fuel specifications and rollout timing with sufficient lead time for project construction.
 - Securing sufficient capital to fund needed construction